

DUPLEX PUMP CONTROL

TDR-24/240V-AA8-X

March 1, 2017

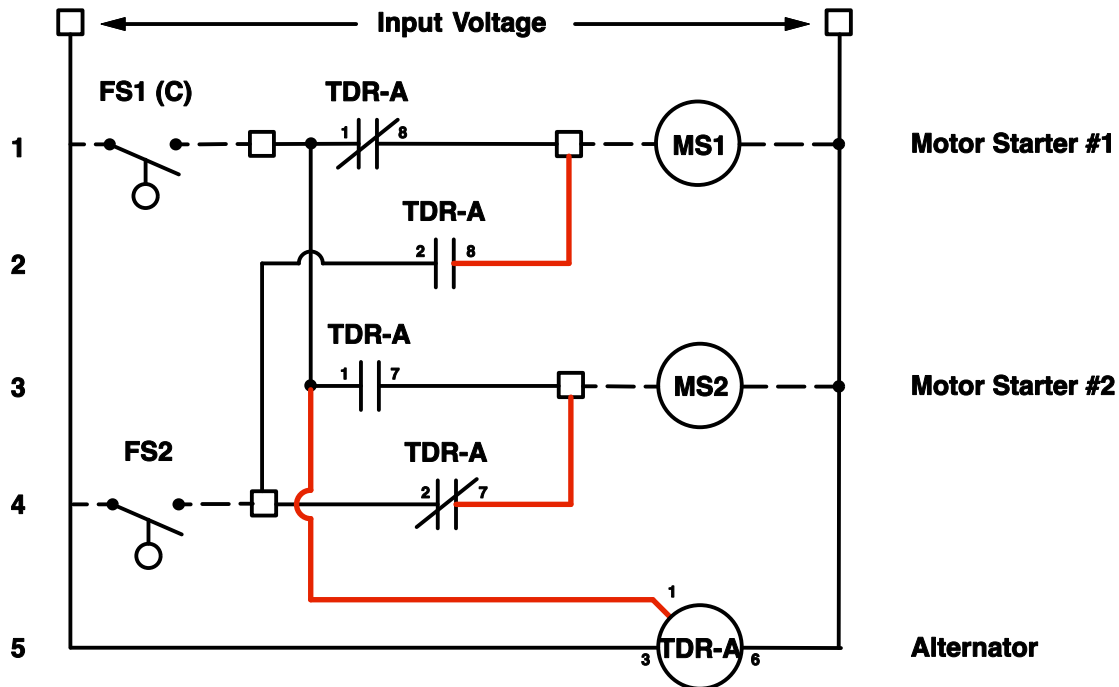

The 3 wires shown in red are internal connections to the TDR-A-X. The X-connection saves 3 wires and 6 termination points.

The pin out numbers are for the duplex operation using the X-Connection.

Operation of this schematic is:

FS1 closes - MS1 is energized and a control signal is provided to the TDR-A
 FS1 opens - MS1 is de-energized, the control signal to the TDR-A is lost and the TDR-A changes its output contacts. Open contacts close and closed contacts open.
 FS1 closes - MS2 is energized and a control signal is provided to the TDR-A
 FS1 opens - MS2 is de-energized, the control signal to the TDR-A is lost and the TDR-A changes its output contacts. Open contacts re-open and closed contacts re-close
 As FS1 closes and opens, the pump operation is alternated between MS1 and MS2 on each cycle.

If both float switches close during operation:

FS1 closes - MS1 is energized and a control signal is provided to the TDR-A
 FS2 closes - MS2 is energized
 FS2 opens - MS2 is de-energized
 FS1 opens - MS1 is de-energized, the control signal to the TDR-A is lost and the TDR-A changes its output contacts. Open contacts close and closed contacts open.
 FS1 closes - MS2 is energized and a control signal is provided to the TDR-A
 FS2 closes - MS1 is energized
 FS2 opens - MS1 is de-energized
 FS1 opens - MS2 is de-energized, the control signal to the TDR-A is lost and the TDR-A changes its output contacts. Open contacts re-open and closed contacts re-close